

HAMMER TYPES, EFFICIENCIES AND MODELS IN GRLWEAP

F. RAUSCHE AND A. KLESNEY

GRL Engineers, Inc., Cleveland, Ohio, United States

INTRODUCTION

The wave equation analysis has become an indispensable tool for the pile driving professional. Contractors use the wave equation to optimize equipment selection in the bid process, foundation engineers check their pile designs for driveability, and hammer manufacturers make equipment recommendations to their customers all based on the wave equation analysis. GRLWEAP is one wave equation program that is widely used domestically and internationally by nearly 1500 different firms and organizations, and regularly the program authors hear questions suggesting that additional information on hammer models and performance should be available to civil engineers in general and pile designers and drivers in particular. This paper attempts to advance this effort for open discourse; other related publications include those authored by Rausche, et al. (2004, 2002, 2000) and Thendean, et al. (1996).

The analysis of an impact or vibratory driven pile requires detailed site specific information to formulate the soil, pile, and hammer and driving system models for simulated pile driving behavior. Hammer and driving system present an important subsection of the model and constitute the first segments of its dynamic equation. Early computer programmed adaptations of the first numerical method wave equation credited to E.A.L. Smith (1960) offered for diesel hammers oversimplified models and neglected to address matters relating to hammer combustion. Vibratory hammers were not considered by the early wave equation programs. Since the release of its first 1976 version (Goble, et al., 1976), the GRLWEAP analysis program, then termed WEAP, has included an extensive hammer database or register of hammer models. Today, the updated database compatible with the 2005 version of the GRLWEAP program includes models for a total of 713 different hammers. With the advent of new technologies and manufacture of new models, however, the database is not all inclusive. Despite difficulties in staying abreast of industry developments, the program offers user data entry should information be lacking or in need of modification. Hammer data entry can be straightforward, and entry level users, provided knowledge of basic modeling conventions, can easily construct an approximate model, compare their entry against existing data and study the effects of assumed variables. The following paper aims to improve understanding of how the various hammers function and how the model parameters affect the program performance. Presented information is in part supplementary to that provided in the program documentation entitled Procedures and Models (PDI, 2005). For further information, Appendix A provides the hammer data request forms detailing information necessary to enter a hammer data model and

Appendix B a listing of the database hammer categories and hammer types together with their assigned efficiencies.

Three broad categories of pile driving hammers classified according to the appropriate program model are presented: the Internal Combustion Hammer, the External Combustion Hammer and the Vibratory Hammer.

INTERNAL COMBUSTION HAMMERS

A category consisting of single and double acting diesels (i.e., open end and closed end), Internal Combustion Hammers are in the United States the most commonly encountered machines. Figure 1 presents a diagram of a typical single acting diesel hammer, and Appendix A shows the associated hammer data request forms which list the minimum information required for model entry. Double acting diesel hammers are no longer built, rarely operated and, therefore, will not be discussed further.

In general, the Internal Combustion Hammer consists of a cylinder with exhaust ports and which is closed at the bottom by the impact block, or the anvil as referenced in some alternate literature. Inside the cylinder the piston or ram moves up under the action of the combustion pressures which develop in the combustion chamber during and after impact. Also, the rebounding pile adds to the upward ram motion. During its descent the ram closes the exhaust ports trapping an air volume which is called the initial volume equal to the product of the distance between exhaust ports and impact block (the compressive stroke) and the internal cylinder area plus the final volume of the combustion chamber.

The model for diesel hammers primarily requires information pertaining to the rated energy of the ram and the combustion pressure(s) and volumes. The rated hammer energy equates to the product of the weight of the piston and rated stroke, or an equivalent rated stroke for double acting hammers. The rated energy is decided upon by the hammer manufacturer. It should be based on the hammer's stroke achieved on a test stand where a test stand is defined as a large and stiff pile that has been driven to refusal. In addition to the rated drop height the hammer also has a maximum drop height. In other words under certain circumstances, e.g. in battered pile driving or when the pile develops a particularly strong rebound, the hammer stroke can exceed the rated value.

The ram model consists of several segments that represent approximately a 1 m long ram section. For most diesel hammers, the rams are uniform and the segments therefore have the same fixed mass, length and diameter. The impact block is represented by a single mass and spring stiffness.

The calculation of the pressure in the combustion chamber is divided into three phases: Precompression (beginning with the time of port closure and ending when combustion or impact is imminent), Combustion and Expansion. Combustion and Expansion phases differ for the two different types of fuel injection discussed below: Liquid Injection and Atomized Injection. During the Combustion Phase the chamber pressure increases to the Maximum Combustion pressure and this value is critical for the performance of the hammer model. This maximum pressure value is back calculated by trial and error such that the calculated diesel hammer stroke is equal to the rated hammer stroke when the hammer is analyzed on a theoretical test stand with certain defined properties. Thus, even if all other hammer properties are identical, the calculated performance of a hammer model will be different if the manufacturer's rated energy is different.

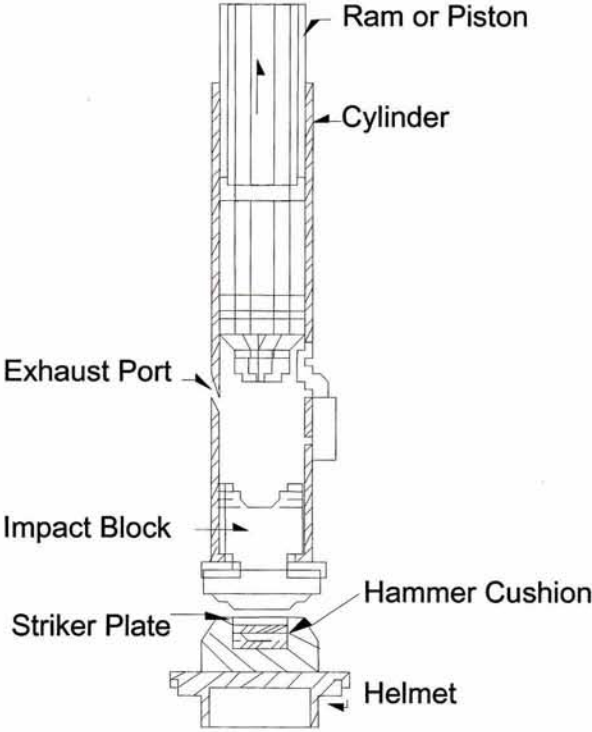

Figure 1. Internal Combustion Hammer, single acting diesel

The diesel hammer model components relating to combustion pressure exhibit a combination of Gas Law calculated and empirically determined phases and require a computational procedure for solution. Both single acting and double acting diesel hammers may draw their fuel for combustion from either liquid or atomized injection, and the analytical procedure depends on the applicable injection model. In either case the hammer stroke has to be calculated by an iterative procedure.

Liquid fuel injection

Liquid injection occurs prior to impact when the combustion chamber is at a relatively low pressure and relies on ram and impact block collision to induce combustion and thus fuel atomization. Fuel atomization is necessary for ignition. Collision also compresses the air to the final combustion chamber volume. As Figures 2 (pressure vs. time) and 3 (pressure vs. volume) demonstrate, upon ignition which occurs after a short combustion delay time, pressure increases during a combustion duration until the maximum pressure is reached. Subsequent pressure decrease, corresponding to upward ram movement and thus expansion of the chamber volume, concludes the cycle and returns the ambient pressure of the chamber to atmospheric pressure upon clearing of the exhaust ports.

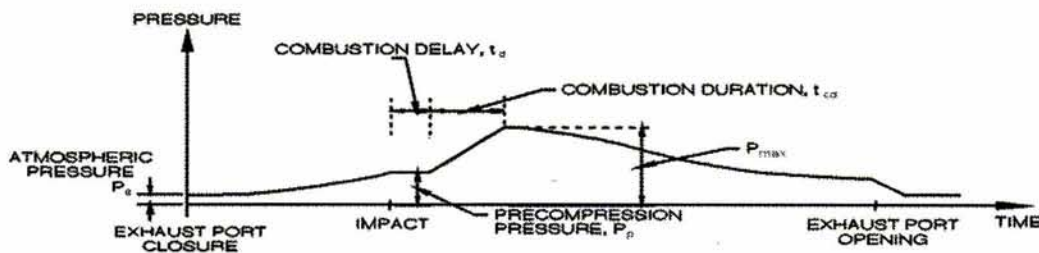

Figure 2. Pressure vs. Time Relationship for Liquid Fuel Injection Model

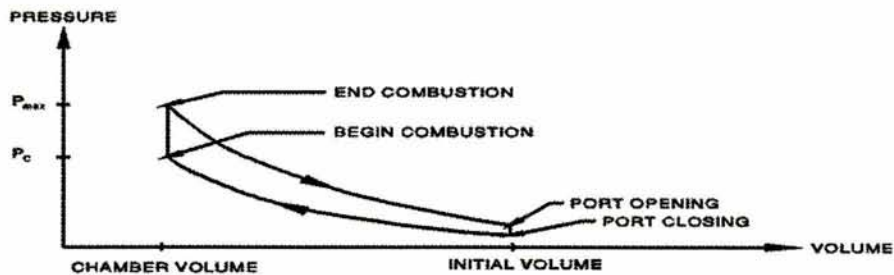

Figure 3. Pressure vs. Volume Relationship for Liquid Fuel Injection Model

Atomized injection

Independent of impact block collision, atomized injection occurs a short duration prior to impact when, due the adiabatic compression, the air temperature is high enough such that the mixing of hot air and atomized fuel causes immediate combustion. Pressure increases, as shown in Figures 4 and 5 according to the quadratic interpolation of the model, following fuel injection to a maximum pressure and corresponding minimum chamber volume upon impact. The maximum pressure is maintained during the initial ascent of the ram until a final combustion volume is reached and atomized fuel injection ceases. As

for the liquid injection model, the ram continues to ascend past the ports and the chamber pressure decreases as a function of the remaining volume until port clearance and return to atmospheric pressure.

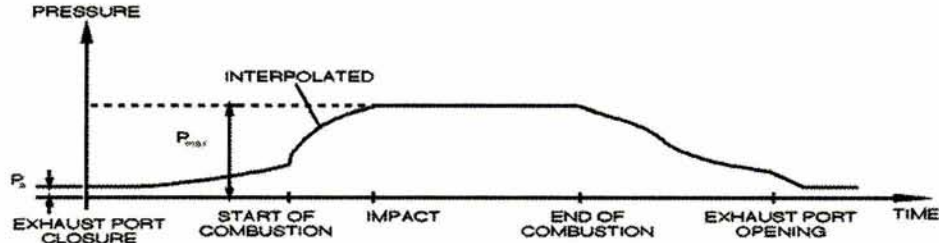

Figure 4. Pressure vs. Time Relationship for Atomized Injection Model

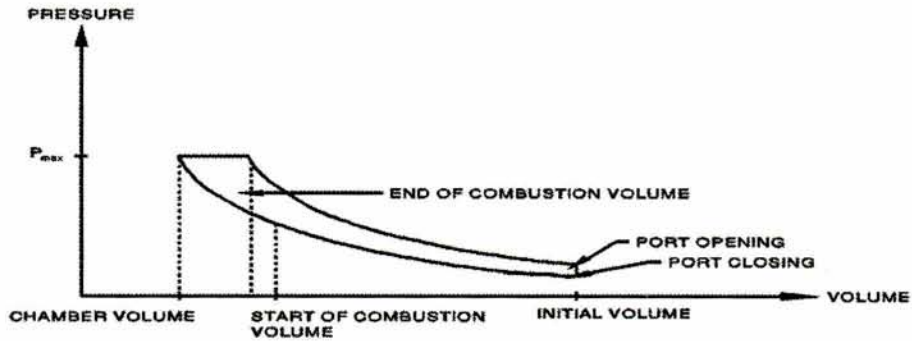

Figure 5. Pressure vs. Volume Relationship for Atomized Injection Model

Significance of Internal Combustion Hammer model parameters

- (1) Ram weight, length and diameter. Together with the maximum combustion pressure (which is dependent on the rated stroke) the ram or piston weight is the most important hammer parameter. Ram weight divided by the number of segments is the individual ram segment weight. Ram length and diameter are of lesser importance as they only define the stiffness of the individual ram springs.
- (2) Impact block weight, length and diameter. These values are converted to one mass and spring stiffness of the impact block. Since the impact block is a passive segment, it filters the impact force pulse to some degree, but does not have a major impact on the hammer performance.
- (3) Compressive stroke, combustion chamber volume, cylinder diameter. These three quantities define the compression ratio of the hammer. A high compression ratio causes high pressures

in the combustion chamber prior to impact. These precompression pressures slow the ram down while at the same time applying a precompression force on pile and soil and thereby helping the pile driving process. However, a high compression ratio causes a reduction of the energy that is transferred from the ram to the pile and thus can reduce the effectiveness of the hammer at high driving resistances. Note: while the compression ratio has an effect on the actually developed maximum combustion pressure, in the GRLWEAP model no link exists between compression ratio, fuel amount (not a GRLWEAP model parameter) and maximum combustion pressure.

- (4) Efficiency. This is another important quantity that has a direct effect on calculated stresses and driving resistance. Just before impact, GRLWEAP reduces the ram velocity by a factor which is related to the efficiency. This ram velocity reduction is thought to remove all of the "incalculable" energy losses such as friction, hammer-pile misalignment etc. The hammer efficiency is set for all diesel hammers to 0.8 which means that roughly 20% of the ram's energy is lost due to some unknown reason prior to impact. If the diesel hammer is equipped with internal energy monitoring then the wave equation analyst may be able to calculate a different hammer energy.
- (5) Maximum combustion pressure. This is also an important quantity as it directly affects the calculated stroke and therefore transferred energy. As discussed, Pmax is back-calculated from the rated stroke value. For multi-step fuel pumps, GRLWEAP's data file also contains additional maximum combustion pressure values corresponding to reduced hammer settings. However rather than back calculating them from the manufacturer's approximate energy ratings, Pmax for reduced hammer settings is typically 90% of the next higher pressure value. An exception is the DELMAG D30 hammer which had a 10-step fuel pump; for this hammer 5 pressure values are given corresponding to settings 10, 8, 6, 4 and 2.
- (6) Time delay and Combustion duration. These two values are the combustion timing values for the liquid injection model. Chosen between ½ and 2 milliseconds, they have relatively little effect on the performance of the hammer model. Actual pressure measurements showed that these two values vary with hammer temperature. In fact if the hammer overheats ignition may occur prior to impact. This is called pre-ignition and causes a self-cushioning of the hammer impact. The program user may investigate such effects by setting the time delay to a negative value (e.g., -5 milliseconds).
- (7) Combustion start and final volume. These values define the timing of the atomized injection. They have a very strong effect on the performance of the hammer model. For example, if the starting volume is reduced, more pre-ignition and thus reduced transferred energies occur. If the ending volume is reduced atomized injection occurs for a longer time period and the hammer then obtains a higher stroke and energy.

- (8) Maximum and Rated stroke. As discussed the rated stroke is defined by the manufacturer's rated energy and therefore has a decisive effect on the theoretical performance of the hammer. In contrast, the maximum stroke only then has an effect when the calculated stroke exceeds the maximum stroke. The program then automatically reduces the maximum combustion pressure value.
- (9) Round-out and Coefficient of restitution. These quantities have relatively little effect on the analysis outcome and since their accurate determination is practically impossible, they should be left at their standard values.

EXTERNAL COMBUSTION HAMMERS

While the energy source of the internal combustion hammer is self-contained in the combustion chamber, the large group of External Combustion Hammers relies on an external source of mechanical energy. This energy, depending on the hammer, may be derived from compressed air, steam, hydraulic fluid or rope release. Regardless of the hammer subcategory, the model as a simplification approximates the hammer operation by estimating the ram velocity immediately prior to impact. Therefore, for the different hammer subcategories, the program operates no different. The subcategories are, however, differentiated by their characteristic efficiency values that have been built into the hammer data file. Impact velocity depends only on the (equivalent) stroke and the hammer efficiency. The (equivalent) stroke is either the rated hammer energy or another operator chosen energy divided by the ram weight. The components that supply and transfer energy to the hammer inlet are immaterial to the GRLWEAP hammer model. A sketch of a common external combustion hammer is presented in Figure 6 and the model data form is included in Appendix A.

The hammer assembly, roughly defined as all hammer components excluding the ram and the attached piston and piston rod, exerts a secondary downward force and can have a perceptible effect on the pile and hammer performance. Downward movement of the assembly together with the helmet loads pile and soil prior to impact. This prestressing effect of the soil aids the driving process. Secondly, during impact the helmet and pile are suddenly moving downward removing the support of the assembly which then falls under the effect of gravity. Eventually, also when the pile rebounds, the assembly catches up with helmet and pile and then it comes to the assembly impact (assembly drop) which can add stresses and in rare instances also driveability to the system. In general specific information pertaining to the assembly is either not available or not necessary for analysis accuracy. In most instances is it sufficiently accurate to assume two identical element masses, summing to the hammer weight (not including the helmet) minus the ram weight, connected in series to the helmet by springs of equal stiffness. It is the program user's responsibility to assure that the actually used assembly weight equals the value stored in the hammer

data file. Certain hammers can be built with differing assemblies (for example for under water applications).

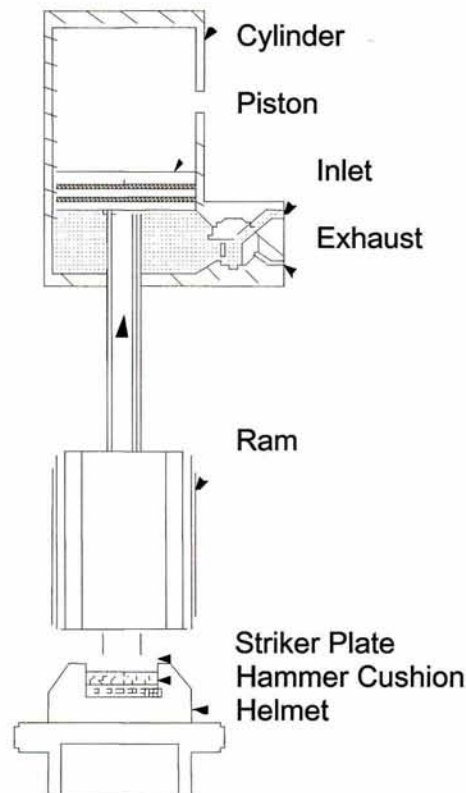

Figure 6. External Combustion Hammer, single acting air hammer

Subcategories of External Combustion Hammers

While there are a large number of different makes, models and operating principles among the external combustion hammers, for the wave equation analyst it is important to make certain simplifications and create easily understandable categories of hammers. The following briefly discusses the categories distinguished. Drop hammers are rarely employed and, therefore, are not discussed.

Single acting air/steam hammers. These are the oldest mechanically powered hammer types. The ram is moved up by compressed air or steam in a cylinder acting against a piston; prior to reaching the rated stroke position the pressure under the piston is released and the ram first coasts on up to the rated stroke and then falls under gravity. Just before hitting bottom the pressure is again allowed to enter the cylinder. Because of the possibility of the ram not reaching full stroke or a pressure increase happening due to pre-admission of motive fluid prior to impact and thus self-cushioning this type of hammer is given a hammer efficiency of 0.67.

Double or differential acting air/steam hammers. In order to make the hammer faster, air or steam pressure is applied to the ram during its descent. This allows for a shorter stroke at the same energy rating. However, this hammer is more complex and timing issues are more critical than for the single acting hammers. Also in hard driving, the hammer can experience uplift (the pile and thus the ram rebound too strongly) and the operator is forced to reduce the pressure and thus the energy of the hammer. For these reasons this hammer type is given a hammer efficiency of 0.5.

Double acting hydraulic hammers. These hammers have similar working principals and deficiencies as their air/steam cousins and are therefore also assigned a hammer efficiency of 0.5.

Power assisted hydraulic hammers. Actually these hammers do not distinguish themselves strongly from the double acting hydraulic hammers except that a small amount of downward pressure is only applied to the ram during its fall and thus no energy reduction occurs in hard driving. Also, these hammers are generally of a modern design that avoids the shortcomings of improper valve timing and thus self-cushioning. The hammer is therefore assigned a hammer efficiency of 0.8.

Hydraulic drop hammers. These are single acting hammers where the timing of the upward directed hydraulic pressure is such that it prevents pre-admission. Some of these hammers work with relatively short strokes and associated with that very high efficiencies in excess of 90% have been observed. However, because of uncertainties of stroke settings and potential friction effects, GRLWEAP assigns these hammers also a hammer efficiency of 0.8.

Hammers with internal monitoring. The most sophistic external combustion hammer is one that measures the ram velocity immediately prior to impact. The hammer energy is then based on the measured kinetic energy which means that all losses have already been accounted for. For that reason the hammer efficiency only has to account for losses such hammer-pile misalignment. In this case the hammer efficiency is set to 0.95. Both hydraulic hammers and diesel hammers may be equipped with the energy monitoring device.

Significance of External Combustion Hammer model parameters

- (1) Ram weight, length and diameter. The ram weight is again together with the stroke the most important quantity. It must include all components that add to the impact energy (piston rod, piston, ram point). Length and diameter are less important and are used to calculate a stiffness value. For rams that are not cylindrical, an equivalent diameter has to be calculated that yields the same area as the ram. For the non-uniform ram, the ram model should consist of a limited number of uniform segments, each having a given mass and stiffness. Accuracy is only important

for the ram weights; the wave equation analysis is less sensitive to differences in ram stiffness values.

- (2) Stroke. The stroke is the fall height of single acting hammers and an equivalent value (energy divided by ram weight) for double acting hammers. The stroke input is therefore most important as it provides the actual energy input of the hammer. Normal variability of the stroke is covered by the hammer efficiency. However, when a hammer with internal monitoring is analyzed and its stroke input value calculated from measured energy divided by ram weight, it should be understood that any error in the kinetic energy measurement directly affects the accuracy of the wave equation prediction.
- (3) Assembly weights and stiffness values. As discussed above, it is important that the total assembly weight is correctly reflected in the input. How the weight is distributed between the two masses and the value of the assembly stiffness is of lesser importance since the assembly drop usually imposes pile stresses at a time when the main impact has passed. In the absence of detailed knowledge about the assembly stiffness, GRLWEAP uses a formula for the stiffness calculation that assures that the assembly stiffness causes no numerical problem in the analysis. For cushioned assemblies the assembly stiffness may be lower and the hammer manufacturer should provide the analyst with that stiffness value.
- (4) Round-out and Coefficient of restitution. These quantities have relatively little effect on the analysis outcome and since their accurate determination is practically impossible, they should be left at their standard values.
- (5) Efficiency. Like stroke, efficiency has a direct effect on ram impact velocity and is therefore an important quantity. The efficiency values of the hammer data file represent an average hammer behavior; the program user is urged to modify these values based on actual measurements.

VIBRATORY HAMMERS

Dissimilar in both appearance and function to the internal and external combustion hammers, the vibratory hammer relies on an external energy source to rotate one or more pairs of hammer eccentric masses thereby causing centrifugal forces which produce sinusoidal forces in the pile. Housed in the oscillator, motor or dynamic weight, the eccentric masses rotate in opposing directions such that they generate vertical vibration of a known frequency; horizontal centrifugal forces cancel and thus cause no horizontal motions. The vertical force generated equates to the sum of the centrifugal forces of all eccentric masses. A clamping device transfers the vibrating force to the pile top or and adds to the dynamic weight and therefore to the static downward force component. The standard hammer assembly as shown in Figure 7 consists of the suspended dynamic weight and an upper bias weight. Connected to the motor through springs and/or shock absorbers, the static bias weight isolates the vibration of the oscillator from the crane or excavator. The standard hammer model inputs are reviewed in Appendix A.

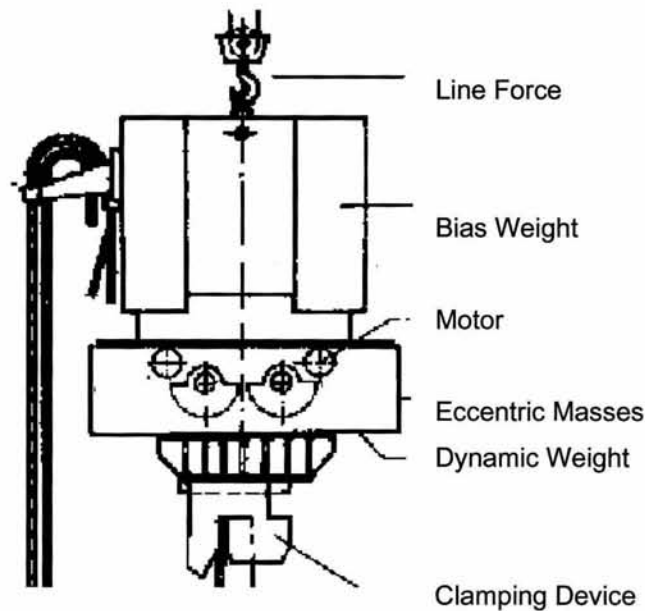

Figure 7. Vibratory Hammer

The vibratory motion of the pile causes both upwards and downwards directed soil resistance effects along the pile shaft while the end bearing only acts in one, the upward, direction. GRLWEAP studies indicate that the driveability of vibratory hammers primarily depends on the ratio of downward forces relative to the end bearing. An important part of the downward forces are the weights of hammer and pile. In fact added weight (or a crowd force) may be very helpful for the successful pile installation by vibration.

Note that the GRLWEAP program can handle only two-mass systems. Vibratory hammers that do not include a bias weight therefore cannot be analyzed by GRLWEAP.

Significance of Vibratory Hammer model parameters

- (1) Top weight. Also known as the bias weight or vibration suppressor, in the GRLWEAP analysis, this mass affects the analysis primarily by adding a downward force to the total system. As mentioned, total weight is important for the driveability of a vibratory system.
- (2) Bottom weight. Also known as the dynamic weight or oscillator, this mass both adds beneficial weight to the driving system and partially filters vibratory forces generated by the eccentric masses.
- (3) Connector spring stiffness. This is the spring of the soft, cushion like elements that separate the top weight from the bottom weight. This value, as well as the associated coefficient of restitution and round-out quantities, has little effect on the analysis outcome.

- (4) Eccentric weight and Radius. Together with frequency these two quantities, representing all eccentric masses, define the vibratory forces and, therefore, are the most important input quantities. Actually, important is the product of eccentric weight and radius and it is therefore sufficient to assume one of the quantities and calculate the other one, if only the eccentric moment has been specified by the manufacturer. A small error would be introduced if the eccentric weight is not exactly known.
- (5) Frequency. Since the vibratory force is a function of the square of the hammer frequency, the higher the frequency the higher the forces and stresses. It is believed that the maximum frequency of a hammer is rather accurately known, however, in the field, the operator may experiment and adjust the frequency to a value that produces the highest rate of pile penetration. Similarly, the GRLWEAP results may show better driveability for lower than maximum frequency.
- (6) Maximum power. Since GRLWEAP checks the power dissipation, it will reduce the vibratory forces if the calculated power output exceeds the manufacturer's value. As such it is important to use a realistic value although high power dissipation only occurs in relatively easy driving where accuracy is not of great importance.
- (7) Efficiency. This value is usually left at unity. Not much is known about vibratory efficiency.
- (8) Line force. The tension force applied at the top of the bias weight. Specified with a negative value it would add to the system's weight in overcoming soil resistance.

SUMMARY

Among similar hammer models and specifically among diesel hammers, minor dissimilarities in models and model components can influence the relative hammer performance. Diesel hammer performance depends largely on the hammer stroke which in turn is calculated from the maximum combustion pressure. This quantity is calculated from the rated energy and the compression ratio. The compression ratio is also responsible for a certain self-cushioning effect and therefore has an effect on calculated stresses and blow counts.

For all impact hammers, while the ram weight and rated stroke (or energy) usually have the dominating effect on calculated stresses and blow counts, the hammer efficiency values provided by the hammer data file do not necessarily reflect the performance of the analyzed hammer and it is important to verify these values in the individual case by measurement.

For the external combustion hammers, many subcategories of hammer models exist. Their operating modes are different and the subcategories assigned by the GRLWEAP approach do not necessarily

reflect the hammer's actual use. For example, a hammer may have been designed with an internal velocity monitoring device, however, this device may malfunction which could lead to an erroneous calculation of stresses and driving resistance.

The vibratory hammer model is relatively simple to model and analyze; however, important questions remain as to the value of both driveability predictions and capacity determination. Experimenting with frequency is suggested. It appears that the highest frequency does not always produce the best driveability and often the hammer is not operated at its highest frequency.

REFERENCES

Pile Dynamics, Inc. (PDI) 2005. GRLWEAP Wave equation analysis of pile driving: Procedures and models, Cleveland, Oh.

Goble, G.G. and Rausche, F. 1976. Wave Equation Analysis of Pile Driving. U.S. Department of Transportation, FHWA, Washington D.C., Implementation Package IP-76-14.1.

Rausche, F., Liang, L., Allin, R., and Rancman, D. 2004. Applications and correlations of the wave equation analysis program GRLWEAP. Proceedings, 7th International Conference on the Application of Stress-Wave Theory to Piles, Petaling Jaya, Selangor, Malaysia, pp. 107-123.

Rausche, F. 2002. Modeling of vibratory pile driving. Proceedings, International Conference on Vibratory Pile Driving and Deep Soil Compaction, Louvain-La Neuve, Belgium.

Rausche, F., Robinson, B., and Seidel, J. 2000. Combining static pile design and dynamic installation analysis in GRLWEAP. Proceedings, 6th International Conference on the Application of Stress-Wave Theory to Piles, São Paulo, Brazil, pp. 59-64.

Smith, E.A.L. 1960. Pile-driving analysis by the wave equation. Proceedings, Journal of the Soil Mechanics and Foundations Division, ASCE, Vol. 86, pp. 35-61.

Thendean, G., Rausche, F., Likins, G.E., and Svinkin, M. 1996. Wave equation correlation studies. Proceedings, STRESSWAVE Conference, Orlando, Fl., pp. 144-162.

APPENDIX A

HAMMER DATA REQUEST FORMS

OPEN END DIESEL HAMMER *-Liquid Fuel Injection*

ID	assigned by GRL	Impact Block
Manufacturer		
Model		IB Weight (kips)
Rated Energy (ft-lbs)		IB Length (in)
Efficiency		IB Diameter (in)

Ram		Combustion Chamber
Ram Weight (kips)		Compressive Stroke (in)
Ram Length (in)		Area (in ²)
Ram Diameter (in)		Final Volume (in ³)

Stroke		Combustion
Maximum Stroke (ft)		Expansion Coefficient
Eq. Rated Stroke (ft)		Delay (sec)
		Duration (sec)

Atomized Injection		Pressure
Ignition Volume (in ³)	Not applicable	Maximum Combustion Pressure (psi)
Final Comb. Vol. (in ³)	Not applicable	

Notes

The Maximum Stroke parameter is the Geometric Maximum distance that the ram can travel before hitting the catch rings; the Equivalent Rated Stroke parameter is Rated Energy divided by Ram Weight.

The undersigned hereby confirms that the above data represents the currently known physical hammer model properties and that this information may be released by Goble Rausche Likins and Associates, Inc. to its clients.

Company	Name (Print)
Signature	Date

OPEN END DIESEL HAMMER *-Atomized Injection*

ID	assigned by GRL	Impact Block
Manufacturer		
Model		IB Weight (kips)
Rated Energy (ft-lbs)		IB Length (in)
Efficiency		IB Diameter (in)

Ram		Combustion Chamber
Ram Weight (kips)		Compressive Stroke (in)
Ram Length (in)		Area (in ²)
Ram Diameter (in)		Final Volume (in ³)

Stroke		Combustion
Maximum Stroke (ft)		Expansion Coefficient
Eq. Rated Stroke (ft)		Delay (sec)
		Duration (sec)
		Not applicable
		Not applicable

Atomized Injection		Pressure
Ignition Volume (in ³)		Maximum Combustion Pressure (psi)
Final Comb. Vol. (in ³)		

Notes

The Maximum Stroke parameter is the Geometric Maximum distance that the ram can travel before hitting the catch rings; the Equivalent Rated Stroke parameter is Rated Energy divided by Ram Weight.

The undersigned hereby confirms that the above data represents the currently known physical hammer model properties and that this information may be released by Goble Rausche Likins and Associates, Inc. to its clients.

Company	Name (Print)
Signature	Date

CLOSED END DIESEL HAMMER *-Liquid Fuel Injection*

ID	<input type="text" value="assigned by GRL"/>	Impact Block	
Manufacturer	<input type="text"/>		
Model	<input type="text"/>	IB Weight (kips)	<input type="text"/>
Rated Energy (ft-lbs)	<input type="text"/>	IB Length (in)	<input type="text"/>
Efficiency	<input type="text"/>	IB Diameter (in)	<input type="text"/>
Ram		Combustion Chamber	
Ram Weight (kips)	<input type="text"/>	C-Stroke (in)	<input type="text"/>
Ram Length (in)	<input type="text"/>	Area (in ²)	<input type="text"/>
Ram Diameter (in)	<input type="text"/>	Final Volume (in ³)	<input type="text"/>
Stroke		Combustion	
Maximum Stroke (ft)	<input type="text"/>	Expansion Coefficient	<input type="text"/>
Eq. Rated Stroke (ft)	<input type="text"/>	Delay (sec)	<input type="text"/>
		Duration (sec)	<input type="text"/>
Bounce Chamber		Atomized Injection	
Compress. Stroke (in)	<input type="text"/>	Ignition Volume (in ³)	<input type="text" value="Not applicable"/>
Area (in ²)	<input type="text"/>	Final Combustion Volume (in ³)	<input type="text" value="Not applicable"/>
Max. Ram Travel (in)	<input type="text"/>		
Distance Safety (in)	<input type="text"/>		
Expansion Coefficient	<input type="text"/>		
C. Tank Volume (in ³)	<input type="text"/>		
Reaction Weight (kips)	<input type="text"/>		
		Pressure	
		Maximum Combustion Pressure (psi)	<input type="text"/>

The undersigned hereby confirms that the above data represents the currently known physical hammer model properties and that this information may be released by Goble Rausche Likins and Associates, Inc. to its clients.

Company	Name (Print)
Signature	Date

CLOSED END DIESEL HAMMER *-Atomized Injection*

ID	<input type="text" value="assigned by GRL"/>	<input type="text" value="Impact Block"/>	
Manufacturer	<input type="text"/>	<input type="text"/> <input type="text"/> <input type="text"/>	
Model	<input type="text"/>		
Rated Energy (ft-lbs)	<input type="text"/>		
Efficiency	<input type="text"/>		
Ram		Combustion Chamber	
Ram Weight (kips)	<input type="text"/>	C-Stroke (in)	<input type="text"/>
Ram Length (in)	<input type="text"/>	Area (in ²)	<input type="text"/>
Ram Diameter (in)	<input type="text"/>	Final Volume (in ³)	<input type="text"/>
Stroke		Combustion	
Maximum Stroke (ft)	<input type="text"/>	Expansion Coefficient	<input type="text"/>
Eq. Rated Stroke (ft)	<input type="text"/>	Delay (sec)	<input type="text" value="Not applicable"/>
		Duration (sec)	<input type="text" value="Not applicable"/>
Bounce Chamber		Atomized Injection	
Compress. Stroke (in)	<input type="text"/>	Ignition Volume (in ³)	<input type="text"/>
Area (in ²)	<input type="text"/>	Final Combustion Volume (in ³)	<input type="text"/>
Max. Ram Travel (in)	<input type="text"/>		
Distance Safety (in)	<input type="text"/>		
Expansion Coefficient	<input type="text" value="typical 1.4"/>	Pressure	
C. Tank Volume (in ³)	<input type="text"/>	Maximum Combustion Pressure (psi)	<input type="text"/>
Reaction Weight (kips)	<input type="text"/>		

The undersigned hereby confirms that the above data represents the currently known physical hammer model properties and that this information may be released by Goble Rausche Likins and Associates, Inc. to its clients.

<input type="text"/>	<input type="text"/>
Company	Name (Print)
<input type="text"/>	<input type="text"/>
Signature	Date

External Combustion Hammer

ID	<input type="text" value="assigned by GRL"/>	Type	
Manufacturer	<input type="text"/>	<input checked="" type="radio"/> Air/Steam Single Acting <input type="radio"/> Air/Steam Double or Differential Acting <input type="radio"/> Traditional Hydraulic Hammer (e.g. converted air/steam) <input type="radio"/> Hydraulic Free Fall Drop Hammer <input type="radio"/> Hydraulic Power Assisted <input type="radio"/> Hydraulic Free Fall Drop Hammer w/ Ram Velocity Measurement <input type="radio"/> Hydraulic Power Assisted w/ Ram Velocity Measurement <input type="radio"/> Cable Suspended Drop Hammer w/ Free Release <input type="radio"/> Cable Suspended Drop Hammer w/ Brake Release	
Model	<input type="text"/>		
Rated Energy (ft-lbs)	<input type="text"/>		
Efficiency	<input type="text"/>		
Ram			
Ram Weight (kips)	<input type="text"/>		
Eq. Ram Length (in)	<input type="text"/>		
Eq. Ram Diameter (in)	<input type="text"/>		
Stroke		Hammer Cushion	
Max. Eq. Stroke (ft)	<input type="text"/>	Material	<input type="text"/>
Min. Eq. Stroke (ft)	<input type="text"/>	Elastic Modulus (ksi)	<input type="text"/>
Assembly Weights		Coefficient of Restitution C.O.R.	<input type="text"/>
Element 1 (kips)	<input type="text"/>	Thickness (in), Area (in ²)	<input type="text"/>
Element 2 (kips)	<input type="text"/>	Helmet	
Element 3 (kips)	<input type="text"/>	Helmet Weight (kips)	<input type="text"/>
Assembly Stiffness		Assembly Notes	
Element 1 (kips/in)	<input type="text"/>	The entire hammer, excluding the ram and the attached piston rod and piston, constitutes the hammer assembly. Typical assembly consists of the hammer base, ram guides, cylinder, and other hammer components of significant weight.	
Element 2 (kips/in)	<input type="text"/>		
Element 3 (kips/in)	<input type="text"/>		

The undersigned hereby confirms that the above data represents the currently known physical hammer model properties and that this information may be released by Goble Rausche Likins and Associates, Inc. to its clients.

Company

Name (Print)

Signature

Date

Vibratory Hammer

ID

Manufacturer

Model

Maximum Power (kW)

Efficiency

Eccentric Mass

Eccentric Moment (in-lbs)

Weight (lbs)

Radius (in)

Weights

Top Weight (kips)

Bottom Weight (kips)

Connector Spring

Stiffness (kips/in)

Rating

Frequency (Hz)

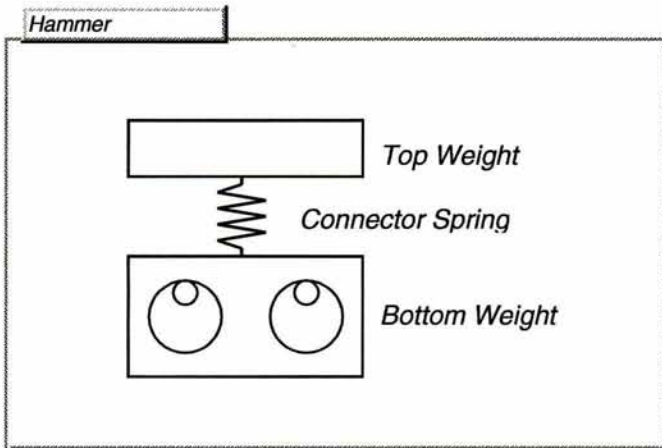

Notes

If only the Eccentric Moment parameter is known, the equivalent Eccentric Weight and Radius will be estimated by GRL as $\text{Eccentric Moment} = \text{Eccentric Weight} * \text{Radius}$.

If the Connector Spring Stiffness parameter is unknown, an approximate value will be estimated by GRL.

The undersigned hereby confirms that the above data represents the currently known physical hammer model properties and that this information may be released by Goble Rausche Likins and Associates, Inc. to its clients.

Company Name (Print)

Signature Date

APPENDIX B

GRLWEAP HAMMER MAKES, TYPES AND EFFICIENCIES

Hammer Make	Hammer Type(s)	Hammer Series	GRLWEAP Hammer Efficiency
(1, 2)			(3)
APE	OED, LF	D	0.80
	ECH, Hydraulic		0.80
	VIB		1.00
Banut	ECH, Hydraulic		0.95
Birmingham	OED, AI or LF	B	0.80
BSP	ECH, Hydraulic	CX, CG, HH, SL	0.80
	ECH, Hydraulic and Instrumented	CX, CG, HH, SL	0.95
Bruce	ECH, Hydraulic	SGH	0.80
Conmaco	ECH, SAAS	C	0.67
Dawson	ECH, Hydraulic	HPH	0.80
Delmag	OED, LF	D	0.80
DKH	ECH, Hydraulic	PH	0.80
	ECH, Hydraulic and Instrumented	PH	0.95
Fairchild	ECH, SAAS	F	0.67
FEC	OED, LF	D, FEC	0.80
HERA	OED, LF		0.80
Hitachi	ECH, Hydraulic	HNC	0.80
	ECH, Hydraulic and Instrumented	HNC	0.95
HMC	ECH, Hydraulic		0.80
	VIB		1.0
HPSI	ECH, Hydraulic		0.80
ICE	OED, LF	I, S	0.80
	CED, AI		0.80
	ECH, Hydraulic		0.80
	VIB		1.0
IHC	ECH, Hydraulic	S, SC	0.80
	ECH, Hydraulic and Instrumented	S, SC	0.95
J&M	ECH, Hydraulic	HIH	0.80
Junttan	ECH, Hydraulic	HHK	0.80
	ECH, Hydraulic and Instrumented	HHK-A, HHU	0.95
Kobelco "Kobe"	OED, LF	K	0.80
Linkbelt	CED, AI	LB	0.80
MAIT	VIB		1.0
Menck	ECH, DA Hydraulic	MH	0.50
	ECH, SAAS	MRBS	0.67
	ECH, Hydraulic	MHF	0.80
	ECH, Hydraulic and Instrumented	MHU	0.95
MGF	VIB	RBH	1.0
Mitsubishi	OED, LF	M, MH	0.80
MVE	OED, LF	M	0.80
MKT	OED, LF	DE	0.80
	CED, LF	DA	0.80
	ECH, SAAS and DAAS	MS, S	0.67
	VIB	V	1.0
Müller	VIB		1.0
Pileco	OED, LF	D	0.80
Pilemaster	ECH, SAAS		0.67
PTC	VIB		1.0
PVE	VIB		1.0
Raymond	ECH, DAAS	R-C, R-CH	0.50
	ECH, SAAS	R	0.67
TWINWOOD	ECH, Hydraulic	V	0.80
	ECH, Hydraulic and Instrumented	V	0.95
Uddcomb	ECH, Hydraulic	H	0.80
Vulcan	ECH, DAAS	VUL-C	0.50
	ECH, SAAS	VUL	0.67

Notes:

- OED - Open End Diesel; CED - Closed End Diesel; ECH - External Combustion Hammer; VIB - Vibratory
- DA - Double Acting; LF (OED) - Liquid Fuel Injection; AI (OED) - Atomized Injection; AS (ECH) - Single and Double Acting Air / Steam; SAAS (ECH) - Single Acting Air / Steam; DAAS (ECH) - Double Acting Air / Steam
- Hammer efficiency assigned in GRLWEAP hammer model